



Operating instructions
Electronic pressure sensor

UK

PI70xx

704104 / 00 06 / 2009

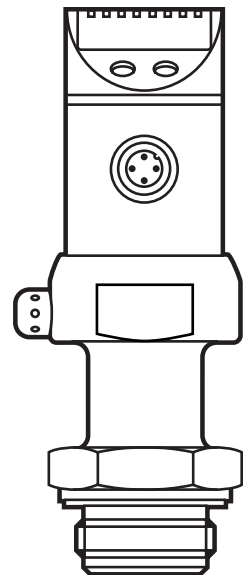

Contents

1	Preliminary note.....	3
1.1	Symbols used	3
2	Safety instructions	3
3	Functions and features	4
3.1	Applications	4
4	Function.....	4
4.1	Processing of the measured signals.....	4
4.2	Pressure monitoring / switching function	5
4.3	Pressure monitoring/ analogue function	5
4.4	Diagnostic function	7
5	Installation.....	8
6	Electrical connection.....	10
7	Operating and display elements	11
8	Menu.....	12
8.1	Menu structure.....	12
8.2	Menu explanation	13
9	Parameter setting	14
9.1	Parameter setting general	14
9.2	Configuring the display (optional).....	16
9.3	Setting the output signal	16
9.3.1	Setting the output function.....	16
9.3.2	Setting the switching limits	17
9.3.3	Scaling the analogue value	17
9.4	User settings (optional).....	18
9.4.1	Zero-point calibration.....	18
9.4.2	Setting the delay time for OUT1	18
9.4.3	Setting the output polarity for OUT1	18
9.4.4	Setting the damping for the switching signal	18
9.4.5	Setting the damping for the analogue signal	18
9.5	Service functions	19
9.5.1	Reading the min./max. values for the system pressure.....	19
9.5.2	Reset all parameters to the factory setting.....	19

10	Operation	19
10.1	Read the set parameter values	19
10.2	Fault indication	19
10.3	Cleaning of the filter cover	20
11	Scale drawing	21
12	Technical data	21
12.1	Setting ranges	23
13	Factory setting	24

1 Preliminary note

1.1 Symbols used

- ▶ Instruction
- > Reaction, result
- [...] Designation of buttons, switches or indications
- Cross-reference



Important note
 Non-compliance can result in malfunctions or interference.

2 Safety instructions

- Read this document before installing the unit. Ensure that the product is suitable for your application without any restrictions.
- Non-adherence to the operating instructions or technical data can lead to personal injury and/or damage to property.
- In all applications check compliance of the product materials (→ chapter 12 Technical data) with the media to be measured.
- For units with cULus approval and the scope of validity cULus → chapter 6 Electrical connection.

3 Functions and features

The pressure sensor detects the system pressure of machines and installations.

3.1 Applications

Type of pressure: relative pressure

Order no.	Measuring range		Permissible overload pressure		Bursting pressure	
	bar	PSI	bar	PSI	bar	PSI
PI7093	-1...25	-14.4...362.7	100	1 450	350	5 070
PI7094	-1...10	-14.5...145	50	725	150	2 175
PI7096	-0.124...2.5	-1.8...36.24	20	290	50	725

$$\text{MPa} = \text{bar} \div 10 \quad / \quad \text{kPa} = \text{bar} \times 100$$



Static and dynamic overpressures exceeding the indicated overload pressure are to be avoided by taking appropriate measures.

The indicated bursting pressure must not be exceeded. Even if the bursting pressure is exceeded only for a short time, the unit can be destroyed.

NOTE: Risk of injury!

4 Function

4.1 Processing of the measured signals

- The unit displays the current system pressure.
- It generates 2 output signals according to the parameter setting.

OUT1	2 selection options <ul style="list-style-type: none"> • switching signal for pressure limit values. • diagnostic signal (in case of a fault output 1 becomes inactive).
OUT2	<ul style="list-style-type: none"> • switching signal for pressure limit values.

4.2 Pressure monitoring / switching function

OUTx changes its switching state if it is above or below the set switching limits (SPx, rPx). The following switching functions can be selected:

- Hysteresis function / normally open: [OUx] = [Hno] (→ fig. 1).
- Hysteresis function / normally closed: [OUx] = [Hnc] (→ fig. 1).

First the set point (SPx) is set, then the reset point (rPx) at the requested distance.

- Window function / normally open: $[OUx] = [Fno]$ (\rightarrow fig. 2).
 - Window function / normally closed: $[OUx] = [Fnc]$ (\rightarrow fig. 2).
- The width of the window can be set by means of the distance between SPx and rPx . SPx = maximum value, rPx = minimum value.

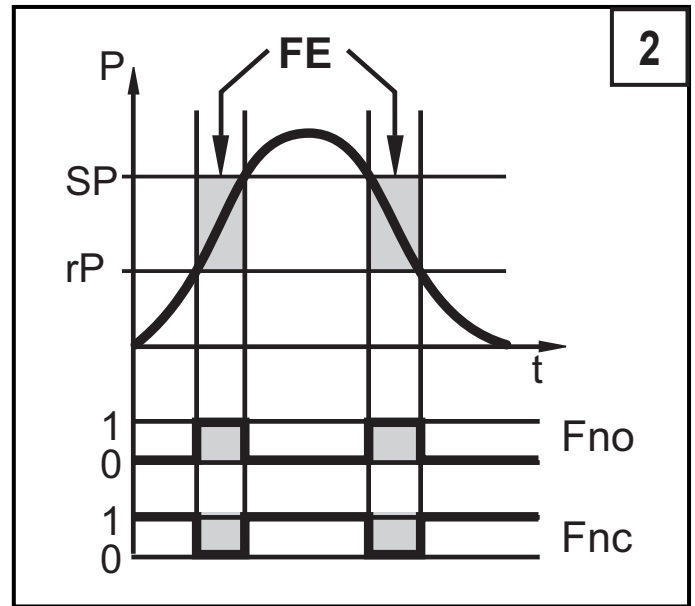
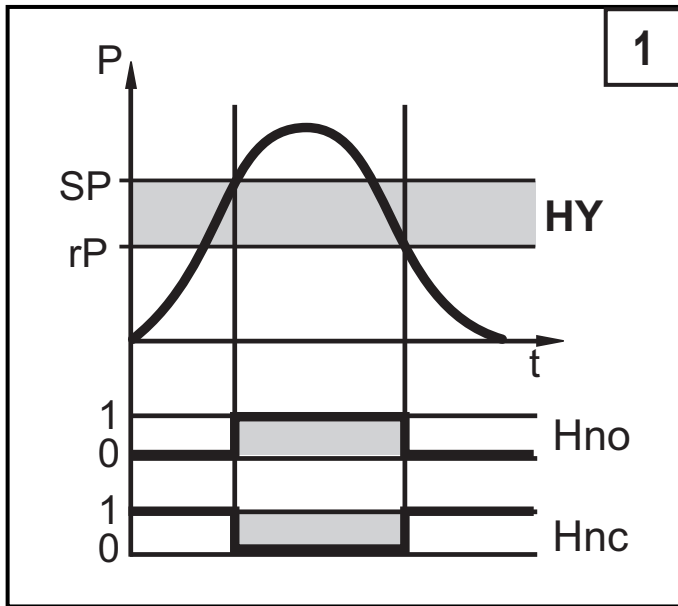

P = system pressure; HY = hysteresis; FE = window

4.3 Diagnostic function

Output 1 is used as a diagnostic output according to DESINA specification if $OU1 = dESI$.

- If there is no fault, the output is switched and carries UB+ (if $P-n = PnP$) or UB- (if $P-n = nPn$).
- In case of malfunctions the output becomes inactive. The following malfunctions are detected:
 - undervoltage (starting with 18 V); overvoltage (starting with 33 V);
 - temperature at the process connection too high ($> 150^{\circ}C$) / too low ($< -30^{\circ}C$);
 - intrinsic temperature of the unit too high ($> 100^{\circ}C$) / too low ($< -30^{\circ}C$);
 - RAM fault.

5 Installation



Ensure that no pressure is applied to the installation while mounting or removing the sensor. Please note: Display „0%“ does not mean that the system is free of pressure!

Horizontal mounting recommended for high medium temperatures.

To monitor a tank:

- ▶ If possible, mount the sensor at the bottom of the tank (1). Do not mount near an agitator (2), a pump (3) or in the spout of the tank (3).

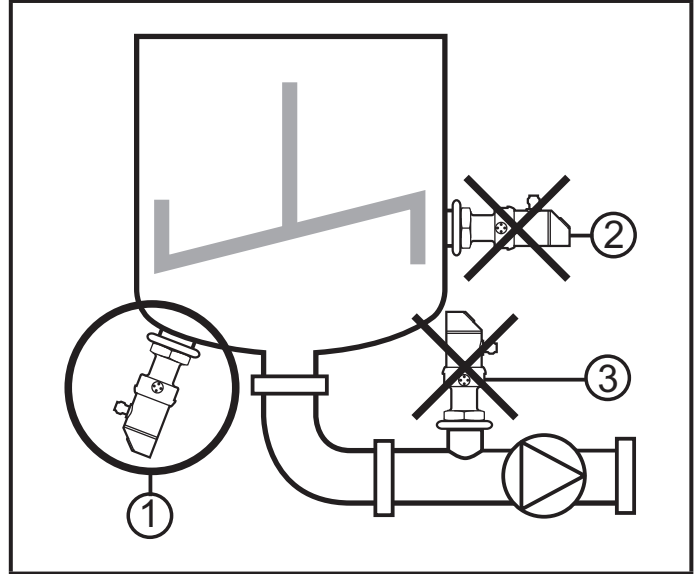

Aseptoflex adapters ensure that the sensor can be connected to different process connections.

(The adapters have to be ordered separately as accessories.)

Mounting operation:

- ▶ Mount the adapter (C) to the sensor.
- ▶ Fix sensor + adapter by means of a coupling nut, a clamp flange or similar (B) to the process connection.

If it is not possible to slide the fixing element (B) down over the top of the sensor: slide it up over the bottom of the sensor before the adapter is mounted.

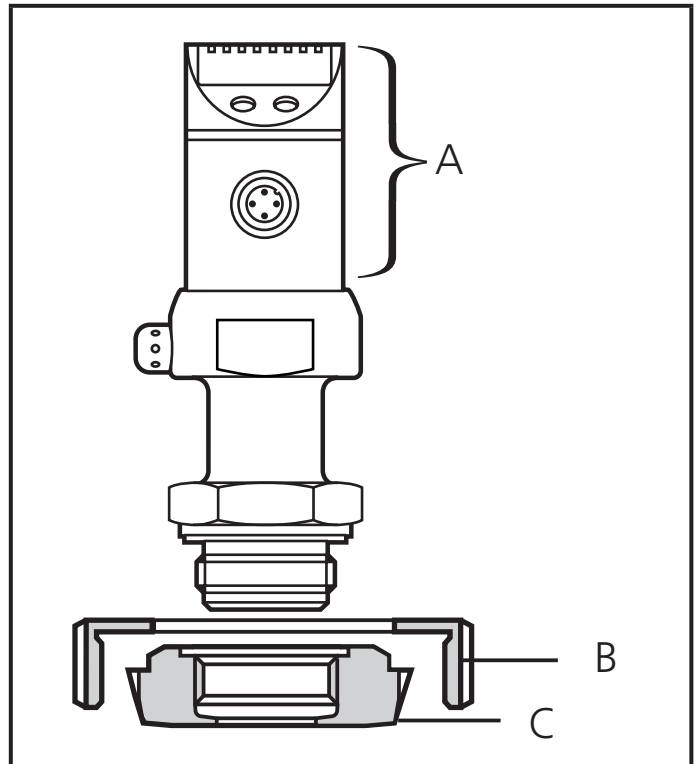

A = rotatable housing

Mounting the Aseptoflex adapter

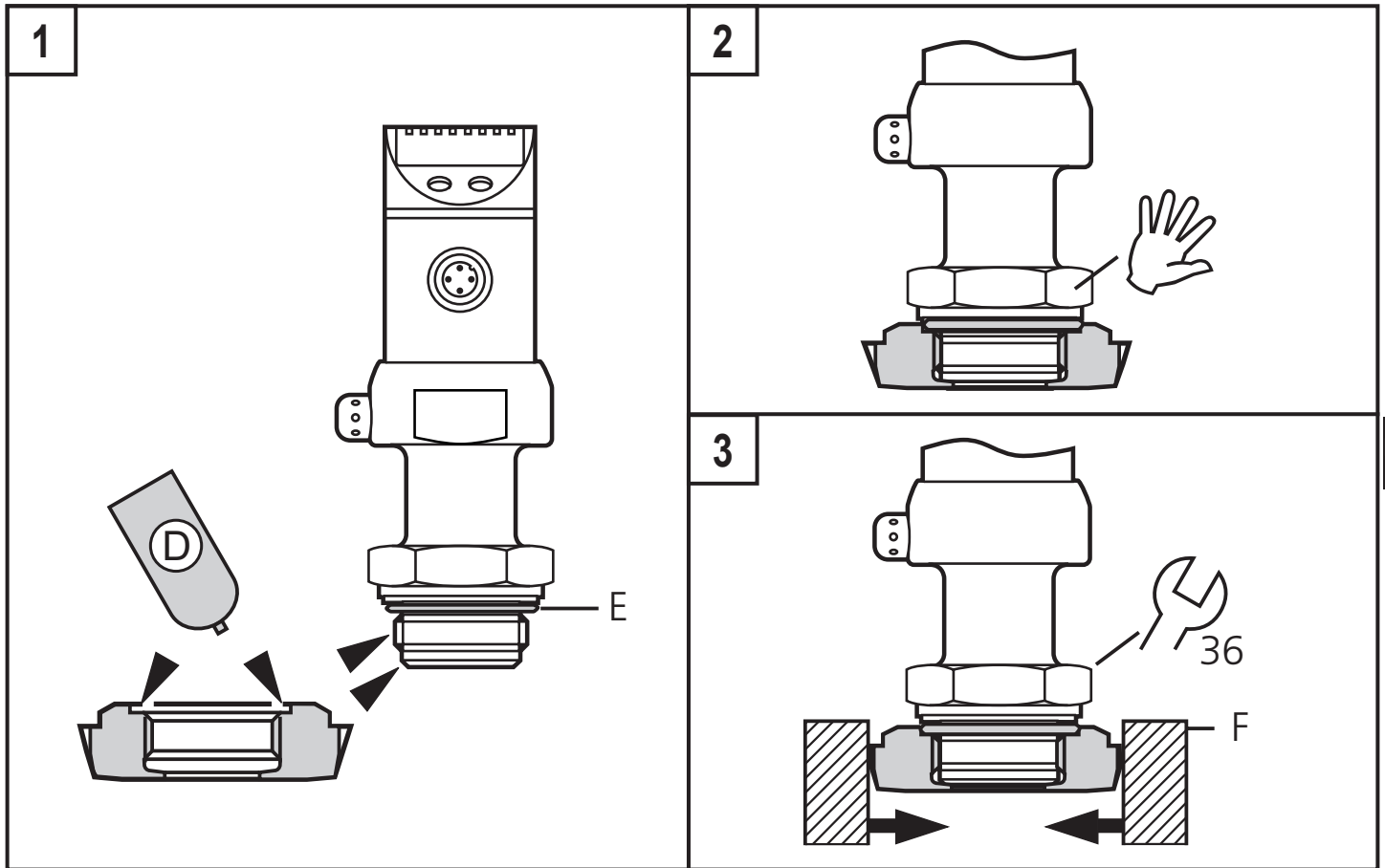

- ▶ Grease the following parts with the paste supplied (D):
 - thread and sealing areas of the unit.
 - sealing areas and O-ring of the adapter.Food-grade paste (USDA-H1 84-201) is supplied. Make sure that the O-ring (E) is correctly positioned.
- ▶ Screw the sensor into the adapter until it is hand-tight. Do not damage the sealing chamfers.
- ▶ Clamp sensor and adapter into a clamping device (F). Tighten the clamping device only slightly so that the adapter does not warp.
- ▶ Tighten the sensor using a spanner until you can feel the end stop (corresponding to a maximum tightening torque of 25 Nm / 18 ftlb). Note: Do not overtighten. This can have an adverse effect on the sealing.

NOTE: A guarantee for a long-term stable and maintenance-free fitting with no bug traps in the hygienic sealing of the metal seal (Aseptoflex connection) is only valid for once-only mounting.

Welding adapter

- ▶ First weld the adapter, then mount the sensor. Follow the instructions included with the adapter.

UK

6 Electrical connection



The unit must be connected by a qualified electrician.

The national and international regulations for the installation of electrical equipment must be adhered to.

Voltage supply to EN50178, SELV, PELV.

For units with cULus approval and the scope of validity cULus: The device shall be supplied from an isolating transformer having a secondary Listed fuse rated as noted in the following table.

Overcurrent protection		
Control-circuit wire size		Maximum protective device rating [A]
AWG	[mm ²]	
22	0.32	3
20	0.52	5
18	0.82	7
16	1.3	10
14	2.1	20
12	3.3	25

► Disconnect power.

► Connect the unit as follows:

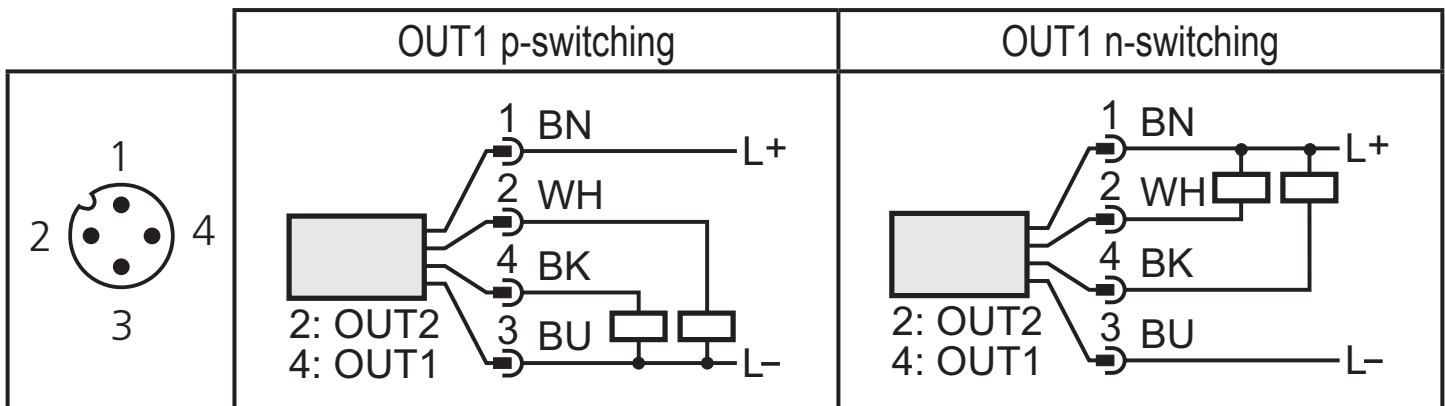

Pin 1	Ub+
Pin 3	Ub-
Pin 4 (OUT1)	<ul style="list-style-type: none"> • binary switching output for pressure monitoring • diagnostic output if [OU1] = [dESI]
Pin 2 (OUT2)	<ul style="list-style-type: none"> • binary switching output for pressure monitoring

Core colours of ifm sockets:

1 = BN (brown), 2 = WH (white), 3 = BU (blue), 4 = BK (black)

7 Operating and display elements

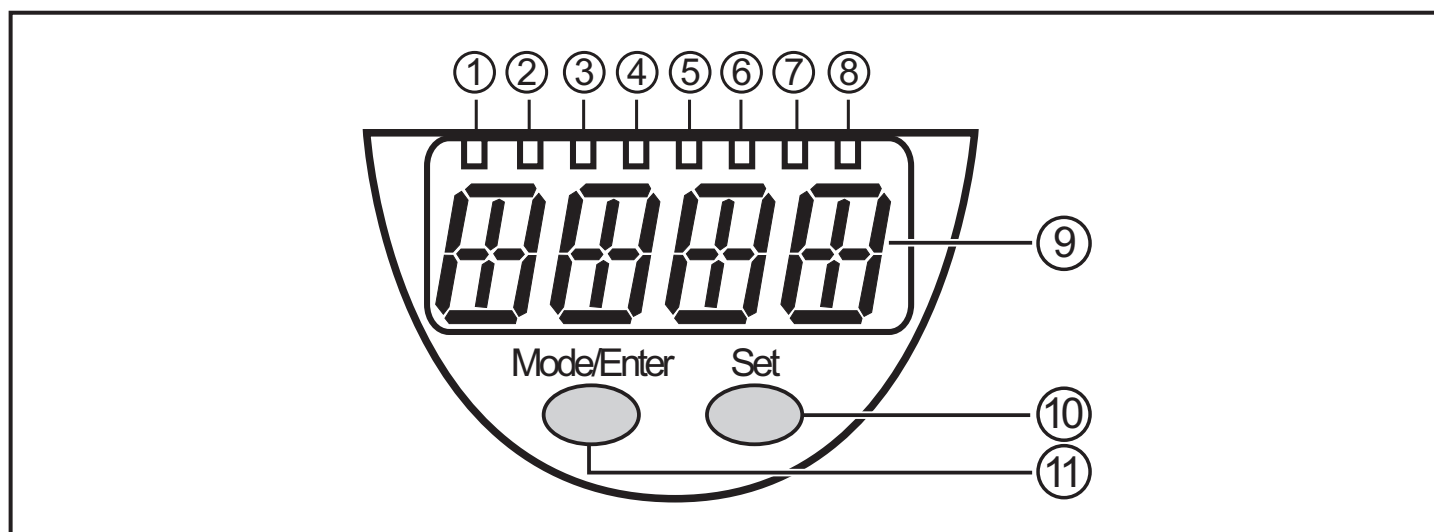

UK

1 to 8: Indicator LEDs

- LED 1 to LED 6 = system pressure in unit of measurement as indicated on the label.
- LED 7, LED 8 = switching state of the respective output

9: Alphanumeric display, 4 digits

- Indication of the current system pressure.
- Indication of the parameters and parameter values.

10: Set pushbutton

- Setting of the parameter values (scrolling by holding pressed, incremental by pressing briefly).

11: Mode/Enter pushbutton

- Selection of the parameters and acknowledgement of the parameter values.

8 Menu

8.1 Menu structure

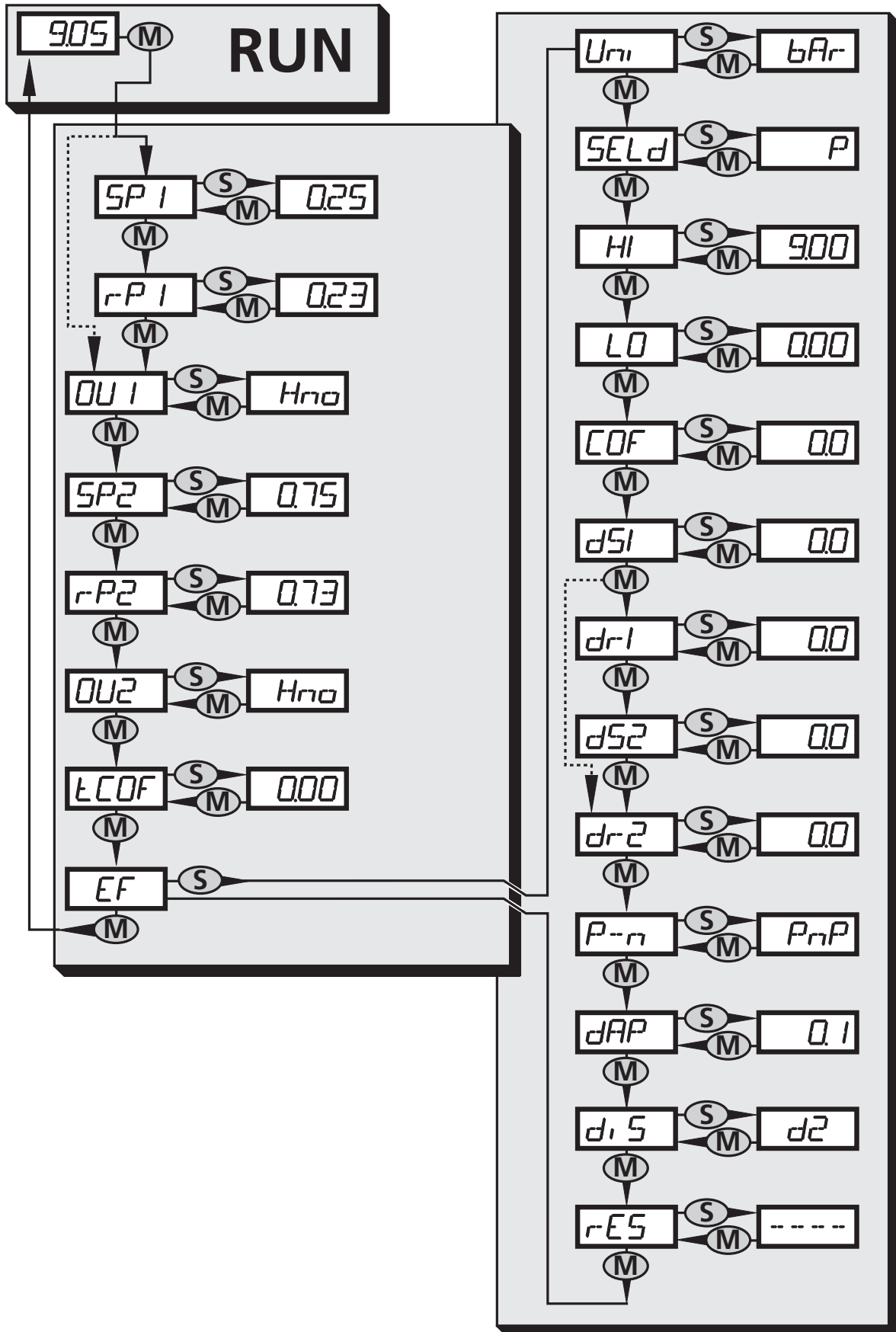

8.2 Menu explanation

SP1/rP1	Maximum / minimum value for system pressure, at which output 1 changes its switching status.
OU1	Output function for OUT1: <ul style="list-style-type: none"> • Switching signal for the limit values: hysteresis function [H ..] or window function [F ..], normally open [. no] or normally closed [. nc] each. • Diagnostic signal [dESI].
SP2/rP2	Maximum / minimum value for system pressure, at which output 2 changes its switching status.
OU2	Output function for OUT2: <ul style="list-style-type: none"> • Switching signal for the limit values: hysteresis function [H ..] or window function [F ..], normally open [. no] or normally closed [. nc] each.
tCOF	Teaching zero-point calibration.
EF	Extended functions / Opening menu level 2.
Uni	Standard unit of measurement for the system pressure.
SELd	Display mode: <ul style="list-style-type: none"> • Pressure in the unit set in [Uni]. • Pressure in percentage value (% of the span).
HI	Maximum value memory for the system pressure.
LO	Minimum value memory for the system pressure.
COF	Zero point calibration.
dS1/dS2	Switch-on delay for OUT1/OUT2.
dr1/dr2	Reset delay for OUT1/OUT2.
P-n	Output polarity: pnp / npn
dAP	Damping for the switching outputs.
diS	Update rate and orientation of the display.
rES	Restore the factory setting.



UK

9 Parameter setting

During the parameter setting process the unit remains in the operating mode. It continues its monitoring function with the existing parameters until parameter setting has been terminated.

9.1 Parameter setting general

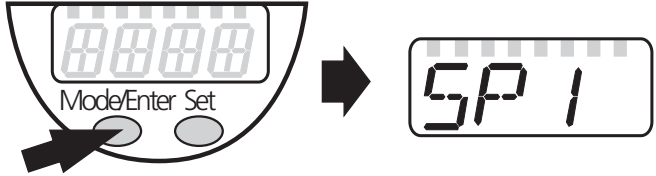
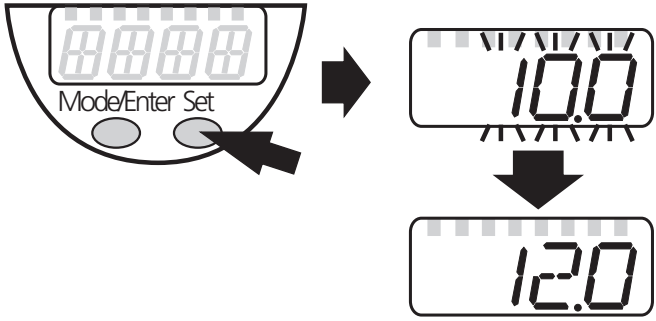
Each parameter setting requires 3 steps:

<p>1</p>	<p>Selecting parameter</p> <ul style="list-style-type: none"> ▶ Press [Mode/Enter] until the requested parameter is displayed. 	
<p>2</p>	<p>Setting the parameter value</p> <ul style="list-style-type: none"> ▶ Press [Set] and keep the button pressed. > Current setting value of the parameter bit flashes for 5 s. > After 5 s: Setting value is changed: incremental by pressing briefly or scrolling by holding pressed. 	
<p>The numerical values are incremented continuously. If the value is to be reduced: Let the display move to the maximum setting value. Then the cycle starts again at the minimum setting value.</p>		
<p>3</p>	<p>Acknowledge parameter value</p> <ul style="list-style-type: none"> ▶ Press [Mode/Enter] briefly. > The parameter is displayed again. The new setting value is stored. 	
<p>Set more parameters</p> <ul style="list-style-type: none"> ▶ Start again with step 1. 		
<p>Finishing parameter setting</p> <ul style="list-style-type: none"> ▶ Press [Mode/Enter] several times until the current measured value is displayed or wait for 15 s. > The unit returns to the operating mode. 		

- Changing from menu level 1 to menu level 2:

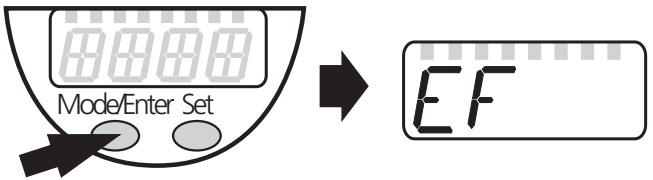
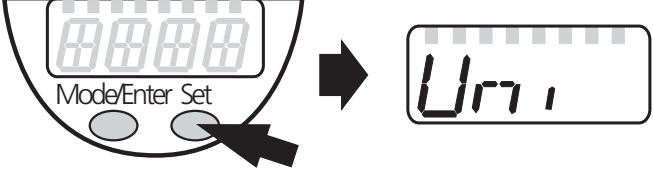
<ul style="list-style-type: none"> ▶ Press [Mode/Enter] until [EF] is displayed. 	
<ul style="list-style-type: none"> ▶ Press [Set] briefly. > The first parameter of the submenu is displayed (here: [Uni]). <p>If menu level 2 is protected by an access code, „Cod1“ flashes in the display.</p> <ul style="list-style-type: none"> ▶ Press [Set] and keep it pressed until the valid code no. is displayed. ▶ Press [Mode/Enter] briefly. <p>Delivery by ifm electronic: no access restriction.</p>	

UK

- Locking / unlocking

The unit can be locked electronically to prevent unintentional wrong settings.

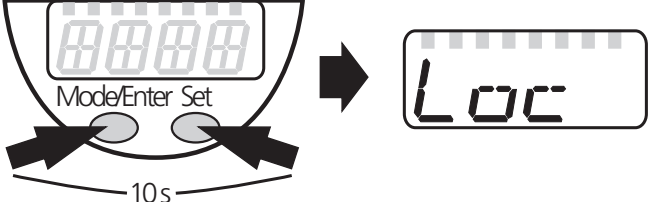
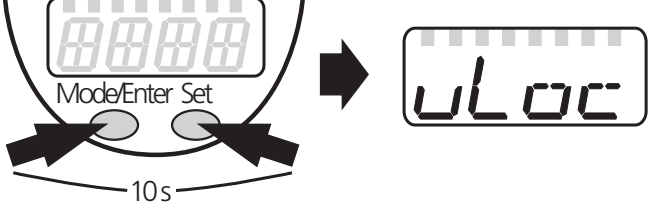
<ul style="list-style-type: none"> ▶ Ensure that the unit is in the normal operating mode. ▶ Press [Mode/Enter] + [Set] for 10 s. > [Loc] is displayed. 	
<p>During operation: [Loc] is displayed briefly when you try to change parameter values.</p>	
<p>For unlocking:</p> <ul style="list-style-type: none"> ▶ Press [Mode/Enter] + [Set] for 10 s. > [uLoc] is displayed. 	

On delivery: Unlocked.

- Timeout:

If no button is pressed for 15 s while the parameters are being set, the unit returns to the operating mode with unchanged values.

9.2 Configuring the display (optional)

<p>▶ Select [Uni] and set the unit of measurement:</p> <ul style="list-style-type: none"> - [bAr], - [MPa], [kPa], - [PSI], - [InHO] (only PI7096), - [mWS] (only PI7096). 	
<p>▶ Select [SELD] and set the display mode:</p> <ul style="list-style-type: none"> - [P]: Pressure in the unit set in Uni. - [P%]: percentage value (pressure in % of the set scaling of the analogue output. The following applies: 0% = ASP value; 100% = AEP value). <p>NOTE: Display „0%“ does not mean that the system is free of pressure.</p>	
<p>▶ Select [diS] and set update rate and orientation of the display:</p> <ul style="list-style-type: none"> - [d1]: Update of the measured value every 50 ms. - [d2]: Update of the measured value every 200 ms. - [d3]: Update of the measured value every 600 ms. - [rd1], [rd2], [rd3]: Display like d1, d2, d3; rotated by 180°. - [OFF]: The display is deactivated in the operating mode. If one of the buttons is pressed, the current measured value is displayed for 15 s. Another press of the Mode/Enter button opens the Display mode. The LEDs remain active even if the display is deactivated. 	

9.3 Setting the output signal

9.3.1 Setting the output function

<p>▶ Select [OU1] and set the switching function:</p> <ul style="list-style-type: none"> - [Hno] = hysteresis function / normally open, - [Hnc] = hysteresis function / normally closed, - [Fno] = window function / normally open, - [Fnc] = window function / normally closed. <p>As an alternative: configure OUT1 as diagnostic output:</p> <p>▶ Select [OU1] and set [dESI].</p>	
<p>▶ Select [OU2] and set the switching function:</p> <ul style="list-style-type: none"> - [Hno] = hysteresis function / normally open, - [Hnc] = hysteresis function / normally closed, - [Fno] = window function / normally open, - [Fnc] = window function / normally closed. 	

9.3.2 Setting the switching limits

<ul style="list-style-type: none"> ▶ Select [SP1] / [SP2] and set the value at which the output switches. 	<p>SP 1 SP 2</p>
<ul style="list-style-type: none"> ▶ Select [rP1] / [rP2] and set the value at which the output switches back. rPx is always lower than SPx. The unit only accepts values which are lower than SPx. 	<p>r-P 1 r-P 2</p>

9.4 User settings (optional)

9.4.1 Zero-point calibration

<ul style="list-style-type: none"> ▶ Select [COF] and set a value between -5% and 5% of the final value of the measuring range. The internal measured value "0" is shifted by this amount. 	<p>COF</p>
<p>As an alternative: Automatic adaptation offset (setting range 0 bar \pm5%); e.g. in the event of a deviation of the mounting location of the sensor and the zero point level for level measurement.</p> <ul style="list-style-type: none"> ▶ Make sure that no pressure is applied to the system. ▶ Press [Mode/Enter] until [tCOF] is displayed. ▶ Press [Set] and keep the button pressed. > The current offset value (in %) briefly flashes, then the current system pressure (in the selected display unit) is displayed. ▶ Release [Set]. ▶ Press [Mode/Enter] briefly to confirm the new offset value. 	<p>tCOF</p>

9.4.2 Setting the delay time for the switching outputs

<p>[dS1] / [dS2] = switch-on delay for OUT1 / OUT2. [dr1] / [dr2] = switch-off delay for OUT1 / OUT2.</p> <ul style="list-style-type: none"> ▶ Select [dS1], [dS2], [dr1] or [dr2], set value between 0.1 und 50 s (at 0.0 the delay time is not active). 	<p>dS 1 dS 2 dr 1 dr 2</p>
--	--

9.4.3 Setting the output polarity

<ul style="list-style-type: none"> ▶ Select [P-n] and set [PnP] or [nPn]. 	<p>P--n</p>
--	-------------

9.4.4 Setting the damping for the switching outputs

<ul style="list-style-type: none">▶ Select [dAP] and set value between 0.1 and 100.0 s (at 0.0 = [dAP] is not active). <p>dAP value = response time between pressure change and change of the switching status in seconds.</p> <p>[dAP] influences the switching frequency: $f_{\max} = 1 \div 2dAP$.</p> <p>[dAP] also affects the display.</p>	
---	---

9.5 Service functions

9.5.1 Reading the min./max. values for the system pressure

<ul style="list-style-type: none">▶ Select [HI] or [LO], press [Set] briefly. <p>[HI] = maximum value, [LO] = minimum value.</p> <p>Delete memory:</p> <ul style="list-style-type: none">▶ Select [HI] or [LO].▶ Press [SET] until [----] is displayed.▶ Press [MODE/ENTER] briefly.	
--	---

9.5.2 Reset all parameters to the factory setting

<ul style="list-style-type: none">▶ Select [rES]▶ Press [SET] until [----] is displayed.▶ Press [MODE/ENTER] briefly. <p>It makes sense to note down your own settings before executing the function (→ 13 Factory preset).</p>	
---	--

10 Operation

After power on of the supply voltage the unit is in the Run mode (= normal operation). It carries out its measurement and evaluation functions and generates output signals according to the set parameters.

Operation indicatin → chapter 7 Operating and display elements.

10.1 Read the set parameter values

- ▶ Press [Mode/Enter] until the requested parameter is displayed.
- ▶ Press [Set] briefly.
- > The unit displays the corresponding parameter value for about 15 s. After another 15 s the unit returns to the Run mode.

10.2 Fault indication

[OL]	Overload pressure (measuring range exceeded).
[UL]	Underpressure range (measuring range below the minimum value).
[SC1]	Short circuit in OUT1.*
[SC2]	Short circuit in OUT2.*
[SC]	Short circuit in both switching outputs.*
[Err]	Internal fault, invalid input.

*The output concerned is switched off as long as the short circuit exists.

The faults SC1, SC2, SC and Err are indicated even if the display is deactivated.

UK

10.3 Cleaning of the filter cover

If viscous and residues producing media clog the filter cover of the sensor (and thus reduce the measuring accuracy slightly), you can clean it.

- ▶ Unscrew the filter cover (B) (use a pair of pliers with plastic-covered jaws for this).
- ▶ Clean the cover thoroughly.

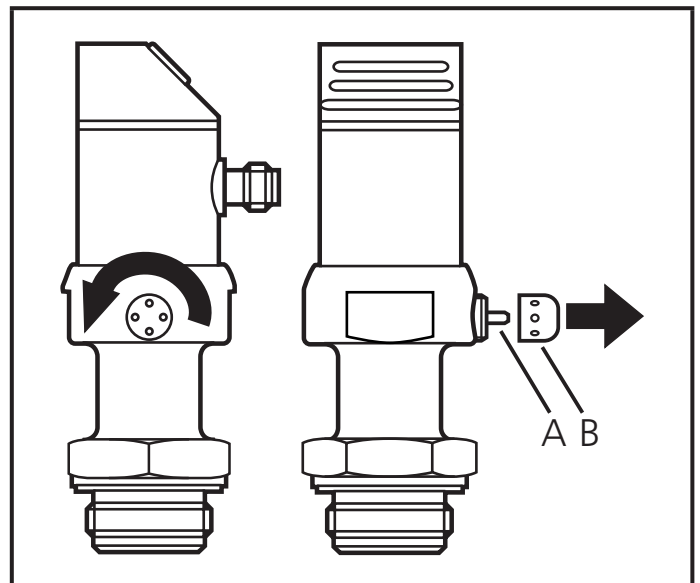

The vent (A) should only be cleaned by skilled personnel and with utmost care. Possible medium residues must not be compressed and pressed into the vent. This could clog the filter system and reduce the measuring accuracy of the sensor.

- ▶ Screw the filter cover again tightly.

11 Scale drawing

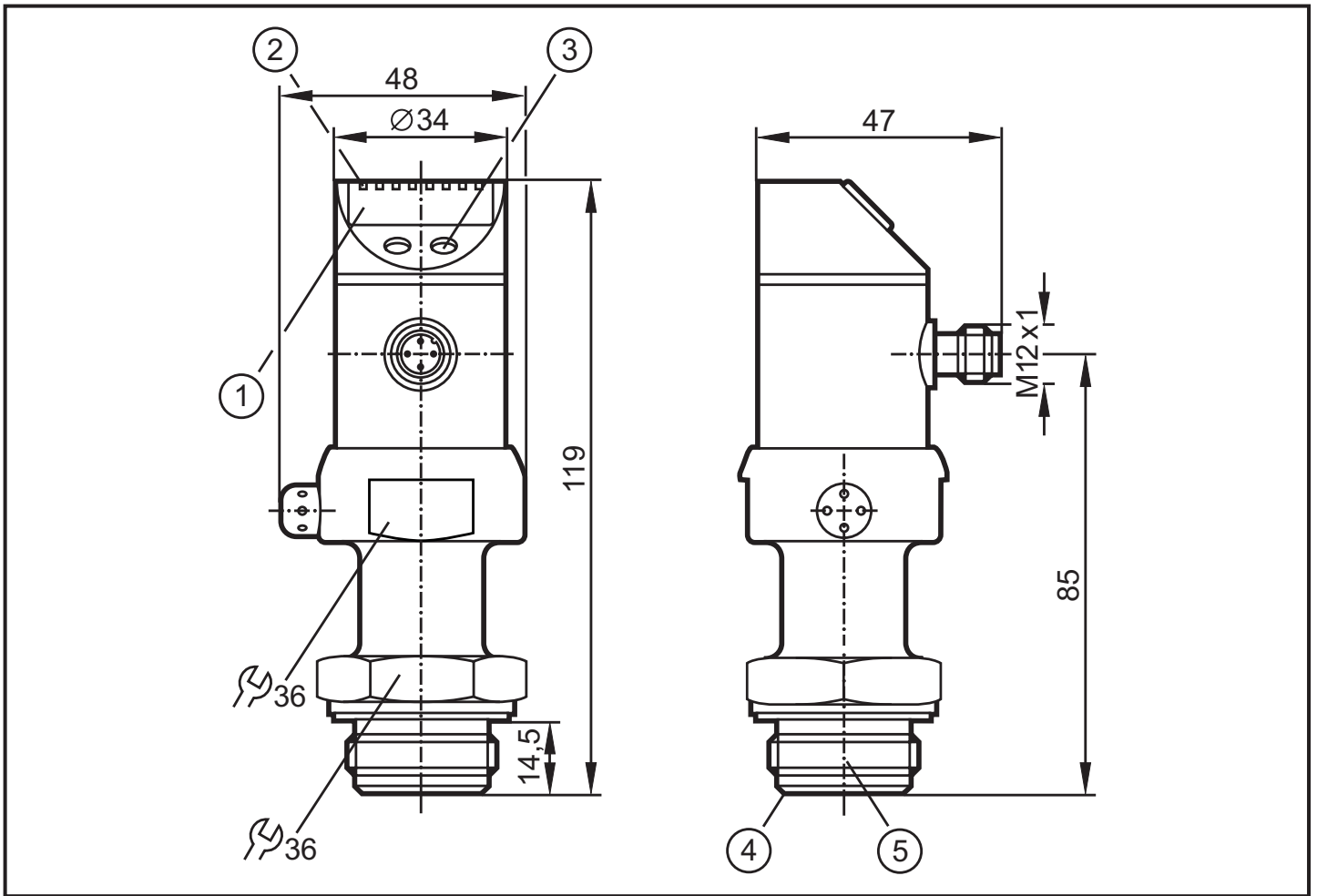

Dimensions are in millimeters

- 1: display
- 2: LED's
- 3: programming button
- 4: Aseptoflex sealing edge
- 5: Aseptoflex thread

12 Technical data

Operating voltage [V].....	18...32 DC
Current consumption [mA].....	< 50
Current rating [mA]	250
Short-circuit / reverse polarity / overload protection, integrated watchdog	
Voltage drop [V]	< 2
Power-on delay time [s].....	0.5
Min. response time switching outputs [ms].....	6
Switching frequency [Hz].....	85

Accuracy / deviation (in % of the span) ¹⁾	
- Characteristics deviation (linearity. incl. hysteresis and repeatability) ²⁾	< ± 0.2
- Linearity.....	< ± 0.15
- Hysteresis.....	< ± 0.15
- Repeatability (with temperature fluctuations < 10 K).....	< ± 0.1
- Long-term stability (in % of the span per year).....	< ± 0.1
- Temperature coefficient (TC) in the compensated temperature range 0 ... 70°C (in % of the span per 10 K)	
- Greatest TC of the zero point	< ± 0.05
- Greatest TC of the span	< ± 0.15
Materials (wetted parts)	
.....	stainless steel 316L / 1.4435, surface characteristics: Ra < 0.4 / Rz 4 ceramics (99.9 % Al ₂ O ₃); PTFE
Housing materials.....	stainless steel 316L / 1.4404; PC (Makrolon); PBT (Pocan); PEI; FPM (Viton); PTFE
Protection	IP 67 / IP 69K
Protection class	III
Insulation resistance [MΩ]	> 100 (500 V DC)
Shock resistance [g]	50 (DIN / IEC 68-2-27, 11ms)
Vibration resistance [g]	20 (DIN / IEC 68-2-6, 10 - 2000 Hz)
Switching cycles min.	100 million
Operating temperature [°C]	-25 ... +80
Medium temperature [°C]	-25...125 (145 max. 1h)
Storage temperature [°C].....	-40...+100
EMC EN 61000-4-2 ESD:	4 / 8 KV
EN 61000-4-3 HF radiated:	10 V/m
EN 61000-4-4 Burst:	2 KV
EN 61000-4-5 Surge:	0.5 / 1 KV
EN 61000-4-6 HF conducted:	10 V

¹⁾ all indications are referred to a turn down of 1:1

²⁾ limit value setting to DIN 16086

12.1 Setting ranges

		SP1 / SP2		rP1 / rP2		ΔP
		min	max	min	max	
PI7093	bar	-0.96	25.00	-1.00	24.96	0.02
	PSI	-13.8	362.7	-14.4	362.1	0.3
	MPa	-0.096	2.500	-0.100	2.496	0.002
PI7094	bar	-0.98	10.00	-1.00	9.98	0.01
	PSI	-14.2	145.0	-14.5	144.7	0.1
	MPa	0.098	1.000	-0.100	0.998	0.001
PI7096	bar	-0.120	2.500	-0.124	2.496	0.002
	PSI	-1.74	36.27	-1.80	36.21	0.03
	kPa	-12.0	250.0	-12.4	249.6	0.2
	inH ₂ O	-48	1004	-50	1002	1
	mWS	-1.22	25.49	-1.26	25.45	0.01

ΔP = increments

13 Factory setting

	Factory setting	User setting
OU1	Hno	
SP1	25% VMR*	
rP1	23% VMR*	
OU2	Hno	
SP2	75% VMR*	
rP2	73% VMR*	
COF / tCOF	0.0	
dS1	0.0	
dr1	0.0	
dS2	0.0	
dr2	0.0	
P-n	pnP	
dAP	0.1	
Uni	bAr / mbAr	
SELd	P	
dis	d2	

UK

* = the indicated percentage of the final value of the measuring range (VMR) of the corresponding sensor in bar / mbar is set.

Technical data and further information at
www.ifm.com → Select your country → Data sheet direct: