



INSTRUCTIONS FOR TWAS-86 ADAPTER SET

The TWAS-86 Adapter Set was designed to provide a simple means of installing a Bimetal Thermometer into an existing Glass Industrial Thermometer Thermowell.

The Adapter Set consists of:

1. An adapter nut.
2. A metal line and spring assembly.
3. A tube of heat conducting medium.
4. A material safety data sheet for the medium.

Selection and installation of a Bimetal Thermometer:

1. Measure the well depth by inserting a pencil, or small diameter rod, into the well until it reaches the bottom (see Figure 1).
2. Using thumb as an index, measure the distance from the end of the pencil to index point (see Figure 2).
3. Refer to the Selection Table (see Figure 3) to select the proper thermometer stem length.
4. Assemble the adapter nut into the well and tighten securely.
5. Coat the lower 3-inch section of the thermometer stem with a layer of heat conducting medium to improve the temperature response of the thermometer.
6. Slide the metal liner over the end of the thermometer stem and apply a layer of heat conducting medium to the outside wall of the liner.
7. Insert the thermometer and liner into the well and tighten into position (see Figure 4).

Note: The metal liner is tapped with a 3/8"-16 machine thread for easy removal from well, if desired.

Where service temperatures exceed 350F, the heat-conducting medium may smoke when first subjected to the high temperature. This is caused by the vehicle in the medium vaporizing and leaving dry solids behind. This should not be cause for alarm. The dry solids will act equally well as a heat-conducting medium for temperatures up to 1000F.

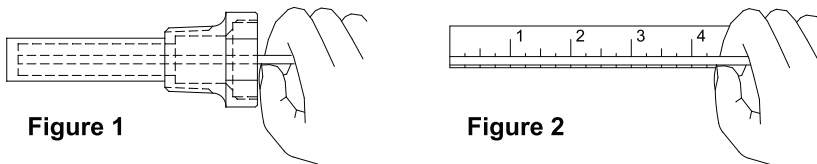

Figure 1

Figure 2

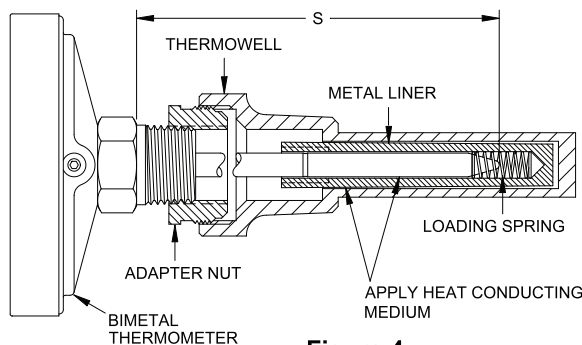

Figure 4

WELL DEPTH IN INCHES	BIMETAL STEM LENGTH S	WELL DEPTH IN INCHES	BIMETAL STEM LENGTH S	WELL DEPTH IN INCHES	BIMETAL STEM LENGTH S
		10		18	
3		11		19	18
4	4	12		20	
5		13	12	21	
6		14		22	
7	6	15		23	
8		16	15	24	
9		17		25	24
10	9	18			

Figure 3